

MASCOT



**High End
Technology**

**Tight
Shutoff**



Reliability

**Expertise you
can trust**

General Products





Who are we?

MASCOT is a culmination of over one hundred years experience in the process control valve industry that brings you a dynamic new team that understands your requirements.

What we offer:

MASCOT, our experience and technology in Severe Service and General Service Valve Applications will bring you solutions to support all your process and control needs. Bringing you global technology and sensible prices. Our distribution and technical support will ensure your requirements are suited.

We specialise in:

- engineering knowledge you can trust
- extensive experience in severe service applications
- risk analysis
- fastest deliveries, quickest response
- training and education

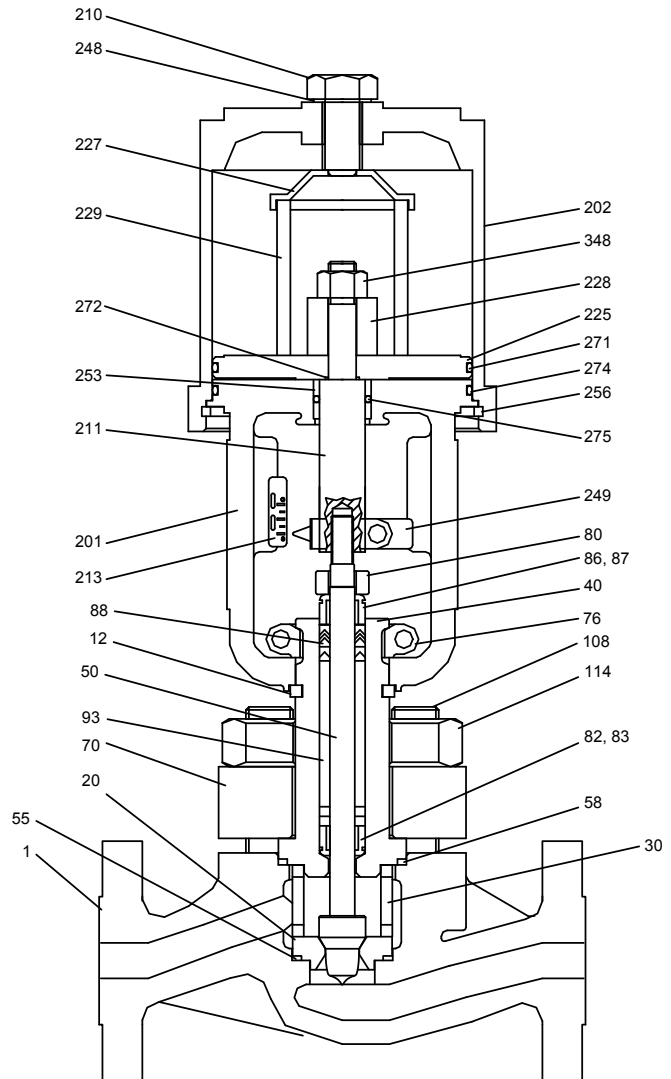

1	Body	201	Yoke
12	Yoke Half Ring	202	Cylinder
20	Seat Ring	210	Adjusting Screw
30	Seat Retainer	211	Actuator Stem
40	Bonnet (Standard)	213	Stroke Plate
50	Plug	225	Piston
55	Seat Ring Gasket	227	Spring Button
58	Bonnet Gasket	228	Actuator Stem Spacer
70	Bonnet Flange	229	Spring
76	Yoke Clamp	248	Adjusting Screw Gasket
80	Gland Flange	249	Stem Clamp
82	Guide Liner Lower	253	Yoke Bush
83	Guide Retainer Lower	256	Retaining Ring
86	Guide Liner Upper	271	Piston O-Ring
87	Guide Retainer Upper	272	Piston Stem O-Ring
88	Packing	274	Yoke O-Ring
93	Packing Spacer	275	Actuator Stem O-Ring
108	Stud	348	Actuator Stem Lock Nut
114	Nut		



General Service

We can supply:

- severe service control valves
- general service control valves
- rotary style control valves
- actuators and positioners
- desuperheaters
- choke valves

Globe Control Valves

- GFLO General Service globe control valve
- GFLO VC Severe Service globe control valve
- GFLO CAVFLO Anti cavitation globe control valve
- GFLO MEGAFLO Noise attenuating globe control valve
- GFLO Y-BODY High flow capacity globe control valve

Rotary Control Valves

- VFLO Characterised V-Ball control valve
- DISKFLO High performance eccentric butterfly valve
- EFLO Eccentric plug valve

Positioners

- HIFLO Pneumatic positioner (3-15 psi)
- HIFLO IP Electro pneumatic positioner (4-20Ma)
- YT2400 Digital Positioner [Hart, Fieldbus, Profibus]

Other Valves

- DEFLO MSD/VSD Desuperheaters
- FLUSHFLO High Performance tank bottom drain valve
- WEIRFLO Diaphragm control valve
- KNIFLO High Performance knife gate valve
- QUICKFLO Actuated and Manual ball valves



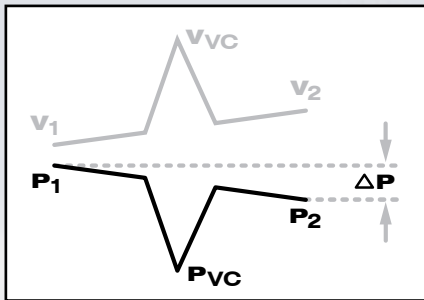

Pressure Profile - single seated valve

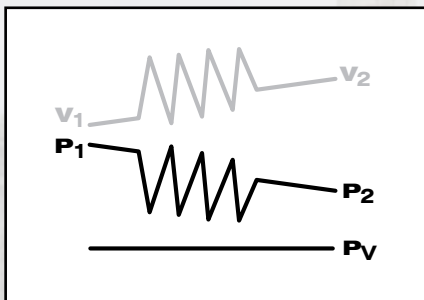

Pressure Profile - Multistage Trim

- P₁** Upstream Pressure
- P₂** Downstream Pressure
- ΔP** Valve Pressure Drop
- P_V** Pressure at Vena Contracta
- P_v** Vapour Pressure
- V₁** Inlet Velocity
- V₂** Outlet Velocity
- V_{VC}** Velocity at Vena Contracta

Severe Service Valves

By utilising mechanisms that convert pressure directly into other forms of energy without passing through a region of low pressure and high velocity, it is possible to eliminate cavitation in liquids, and substantially reduce noise levels in high pressure drop gas applications.

Proper control valve selections will ensure that the required energy can be dissipated without exceeding the maximum vibration levels in the piping system and without exceeding the wear properties of the trim material. The selected control valve trim design shall facilitate maximum reduction of control valve induced vibration and trim wear.

Control valve vibration and trim erosion can be reduced by multi-stage multistage trim designs. In order to minimise vibration, the control valve trim design should be based on ISA Guideline Compliant Specification, edition 1998, Clause 5.3.2.





Variable Spray Desuperheater

The variable nozzle spray Desuperheater represents major advance in the design of Desuperheaters. It is small enough to mount through a 100mm flange in the steam main having a minimum of 6 meters of straight pipe work downstream of the nozzle.

The variable nozzle spray Desuperheater (VSD) provides more economical control of steam temperature by introducing cooling water into the steam flow and through a nozzle of advanced design. In this design water pressure above steam pressure is used to produce a thin film of conical spray of water which evaporates as soon as it is injected into the steam flow. The design of the Desuperheater eliminates the need for a separate water control valve.

The valve is accurately built into the Desuperheater. Because there is no external water control valve and there is always maximum water pressure at the nozzle.

The equal percentage characteristic plug controls the amount of atomized water being injected. As per signals of the temperature controller the valve plug varies the area of the nozzle and the water which is directed through a cage has 12 water inlet orifices, progressively uncovers as per the lift of the plug. Water flow is controlled at the point of injection into the steam.

The VSD Desuperheater utilizes constant water pressure to create a fine conical spray of which is injected into the moving of steam. The Desuperheater water spray evaporates quickly, eliminating the impingement on the piping walls.

The actuator moves the Desuperheater control plug, which regulates the quantity of water not the pressure injected into the steam.

Due to its unique design the VSD Desuperheater offers considerable advantage to the users.

Typical Pressure Reducing and Desuperheating unit (PRDS)

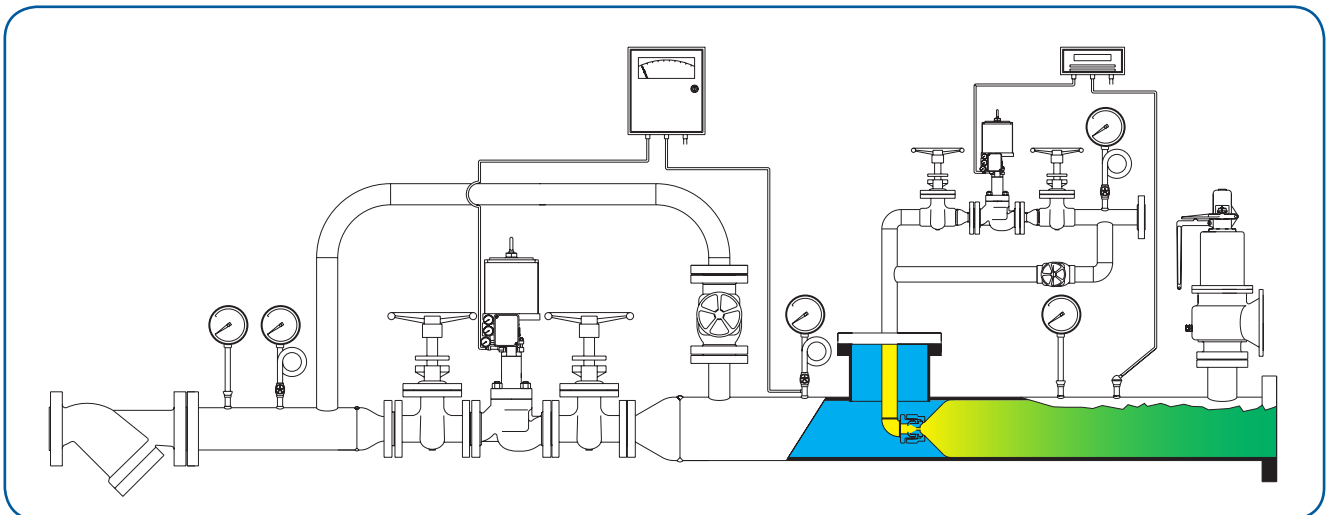

Typical Pressure Reducing and Desuperheating unit (PRDS)



GfLO

High Performance Single Seated Globe Control Valve

Body type: 2way, 3way, angle & jacketed
 Size: 0.5" to 30.0"
 Pressure Class: . . . Up to ANSI CL 4500
 Body Material: . . . All castable alloys
 End Connections: . . Flanged, screwed, butt and socket welded
 Bonnet: Standard, extended, cryogenic & bellow sealed
 Guiding: Heavy duty double top stem
 Gland Packing: . . . PTFE, braided PTFE, grafoil, low fugitive emission
 Gaskets: PTFE, spiral grafoil
 Seat Ring: Clamped-in, self aligned
 Plug: Solid one piece construction with large stem diameter
 Characteristics: . . . Equal percentage, linear and on-off
 Special Trims: . . . CAVFLO, MEGAFLO, GFLO VC
 Actuator: Linear spring cylinder, fully field reversible
 Shut off class: With metal seat - ANSI IV or V and replaceable soft seat - ANSI VI



VfLO

High Performance V-Ball Control Valve

Body type: One-Piece VfLO Ball, straight-through
 Size: 0.5" to 18.0"
 Pressure Class: . . . Up to ANSI CL 900
 Body Material: . . . All castable alloys
 End Connections: . . Flangeless, flanged (integral and separable flange)
 Gland Packing: . . . PTFE, braided PTFE, grafoil
 Seat Ring: Clamped-in, self aligned, bi-directional
 Ball: Segmented V-notch ball, reduces clogging, shearing action fibrous fluids
 Shaft: Splined-No lost motion or dead band
 Characteristics: . . . Equal percentage, linear and on-off
 Rangeability: 300:1
 Actuator: Rotary spring cylinder, fully field reversible
 Shut off class: With metal seat - ANSI IV and replaceable soft seat - ANSI VI



DISKFLO

High Performance Wafer style Butterfly Control Valve

Body type: Wafer, light in weight, provides large flow and minimum pressure drop
 Size: 2.0" to 42.0"
 Pressure Class: . . . Up to ANSI CL 1500
 Body Material: . . . All castable alloys
 End Connections: . . Wafer, lugged, flanged
 Gland Packing: . . . PTFE, braided PTFE, grafoil
 Seat Ring: Clamped-in, self aligned
 Disc: Double eccentric cammed
 Shaft: Splined no lost motion or dead band
 Characteristics: . . . Equal percentage, linear and on-off
 Actuator: Rotary spring cylinder, fully field reversible
 Shut off class: With metal seat - ANSI IV and replaceable soft seat - ANSI VI



SEVERE SERVICE

Cavitation, Noise Abatement, Velocity Control Trim

Applications:

- Anti-cavitation trims
- Noise attenuation trims
- Multistage "velocity control" anti-cavitation
- Trims for liquid applications
- Multistage "velocity control" noise attenuating trims
- Choke applications

MASCOT Industrial

15A Randor Street Campbellfield, Victoria 3061 Australia

Tel: +61 3 9357 6555 | Fax: +61 3 9357 6566 | Email: sales@mascot-industrial.com | Web: www.mascot-industrial.com

The contents of this brochure are provided for informational purposes only. Whilst every effort has been made to ensure the accuracy of the information and specifications provided, they are not to be construed as warranties or guarantees, express or implied, regarding any matter in relation to this product. MASCOT Industrial reserves the right to modify or improve designs and as such the information and specifications provided in this brochure are subject to change without notice. MASCOT Industrial does not accept responsibility for the selection, use and maintenance of any product. Responsibility for the selection, use and maintenance of any product remains with the purchaser and end user.